

# ME-IO 18.8 ...

## Component housing

Data sheet  
105787\_en\_00

© PHOENIX CONTACT 2014-05-08



### 1 Description

The housings of the ME-IO 18.8 ... product range consist of a 18.8 mm wide **lower housing part** with space for the PCB assembly.

The lower housing part can be combined with various housing covers. The lower housing part is subdivided into 9 units (1 Unit = 11 mm). These units can be combined with connectors and housing covers in various ways.

The **connectors** correspond to a unit and have a push-in connection for conductor cross sections of up to 2.5 mm<sup>2</sup>. The connectors are 4-pos., but partially assembled or TWIN variants are also available. All in all, that makes a maximum of 36 positions possible in a single housing. As a counterpart to the connectors, there are **headers** in 2 or 3 unit versions for soldering onto the PCB.

The **housing covers** in 2 to 7 unit versions are especially suited for installing connection systems such as USB or D-SUB as well as display and operating elements. We would be glad to install the required openings for you.

The housings can be snapped onto an NS 35 DIN rail.

It is possible to use the housings with a **DIN rail connector** by means of which communication can be established between the housings, or the supply voltage can be transmitted.



The 3D housing data can be found at [phoenixcontact.net/products](http://phoenixcontact.net/products).



Make sure you always use the latest documentation. It can be downloaded at [phoenixcontact.net/products](http://phoenixcontact.net/products).



This data sheet is valid for all products listed on page 5.

## Table of contents

1	Description.....	1
2	Overview of the ME-IO 18.8 ... products .....	3
3	Ordering data.....	5
4	Technical data .....	5
5	Combination of headers and connectors .....	6
	5.1 Connections of headers and connectors .....	6
	5.2 Selecting headers and connectors .....	6
	5.3 Concatenating headers .....	7
6	Dimensions .....	8
	6.1 External dimensions .....	8
	6.2 Internal dimensions of lower housing part .....	8
	6.3 Dimensions of the housing cover.....	8
7	PCB dimensions .....	9
	7.1 Maximum PCB dimensions in the lower housing part.....	9
	7.2 Maximum PCB dimensions with DIN rail connector.....	10
	7.3 PCB dimensions according to housing cover .....	11
	7.4 PCB with FE contact.....	12
8	Connection technology .....	13
	8.1 Header .....	13
	8.2 Connector.....	16
	8.3 DIN rail connector.....	17
9	Mounting the housing .....	18
	9.1 Assembling the Lock and Release system .....	18
	9.2 Inserting the PCB .....	18
	9.3 Assembling the housing covers.....	19
	9.4 Assembling the connectors .....	19
	9.5 Releasing the connectors (Lock and Release) .....	20
	9.6 Coding the connectors .....	20
	9.7 Connecting conductors (push-in connection).....	21
	9.8 Mounting the housing on a DIN rail.....	21
10	Removing the housing .....	22
	10.1 Taking the housing off the DIN rail.....	22
	10.2 Removing the housing covers .....	22
	10.3 Removing the base latch .....	23
	10.4 Taking out the PCB .....	23
	10.5 Taking off the Lock and Release system .....	24

## 2 Overview of the ME-IO 18.8 ... products

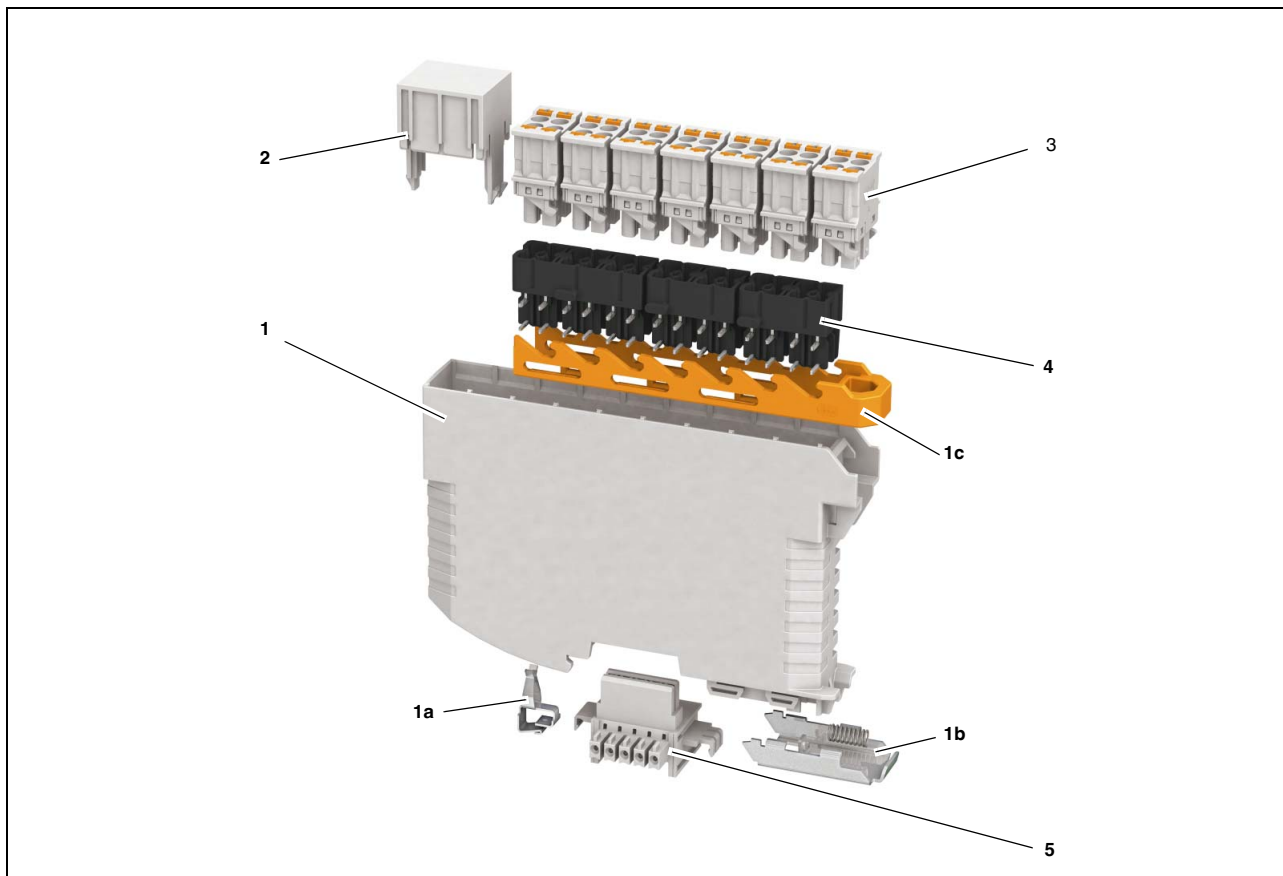

Figure 1 Example of housing structure

- 1 Lower housing part with FE contact (1a), base latch (1b) and Lock and Release system (1c)
- 2 Housing cover
- 3 Push-in connectors
- 4 Headers
- 5 DIN rail connector

The orange lever of the Lock and Release system is used for locking and unlocking the push-in connectors.

The push-in connectors are available in three variants, fully and partially assembled, and as a TWIN connector, on which two positions are each bridged together.

The counter-part to the push-in connectors are the headers.

The housing can be optionally combined with a DIN rail connector by means of which data or the power supply can be transmitted from module to module.

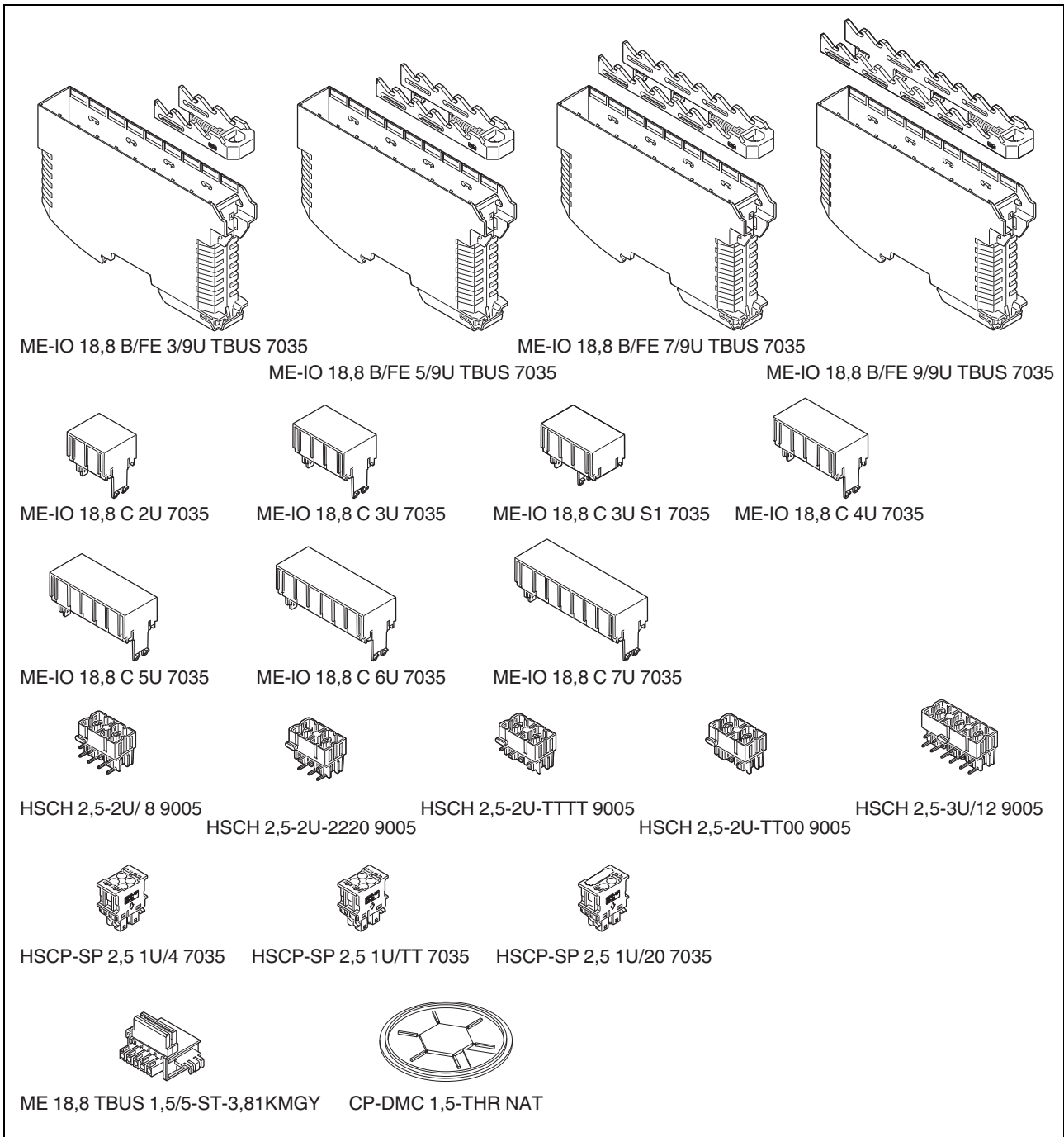

Figure 2 Overview

### 3 Ordering data

#### Component housing

Description	Type	Order No.	Pcs. / Pkt.
<b>Lower housing part</b> , overall width 18.8 mm, pre-assembled, with metal foot catch for DIN rail mounting, integrated FE contact, without DIN rail connector, color: similar to RAL 7035			
Lock and Release system, locking of the connectors to the header, included in the units:			
3 units	ME-IO 18.8 B/FE 3/9U TBUS 7035	2201963	10
5 units	ME-IO 18.8 B/FE 5/9U TBUS 7035	2201962	10
7 units	ME-IO 18.8 B/FE 7/9U TBUS 7035	2201961	10
9 units	ME-IO 18.8 B/FE 9/9U TBUS 7035	2201960	10
<b>Housing cover</b> for various units, color: similar to RAL 7035			
2 units	ME-IO 18.8 C 2U 7035	2201799	10
3 units	ME-IO 18.8 C 3U 7035	2201800	10
3 units (covers 2 units and 1 unit with header)	ME-IO 18.8 C 3U S1 7035	2201801	10
4 units	ME-IO 18.8 C 4U 7035	2201802	10
5 units	ME-IO 18.8 C 5U 7035	2201803	10
6 units	ME-IO 18.8 C 6U 7035	2201804	10
7 units	ME-IO 18.8 C 7U 7035	2201805	10
<b>Header</b> , touch-proof, color: similar to RAL 9005			
2 units, 8 connections	HSCH 2.5-2U/ 8 9005	2201789	50
2 units, 6 connections	HSCH 2.5-2U-2220 9005	2201792	50
2 units, 4 connections	HSCH 2.5-2U-TTTT 9005	2201790	50
2 units, 2 connections	HSCH 2.5-2U-TT00 9005	2201791	50
3 units, 12 connections	HSCH 2.5-3U/12 9005	2201788	50
<b>Push-in connector</b> , for headers, for conductor cross section 2.5 mm <sup>2</sup> , with integrated test connection, color: similar to RAL 7035			
1 unit, 4 pos., fully assembled	HSCP-SP 2.5 1U/4 7035	2201780	50
1 unit, 2 TWIN connections	HSCP-SP 2.5 1U/TT 7035	2201781	50
1 unit, 2 pos., partially assembled	HSCP-SP 2.5 1U/20 7035	2201782	50
<b>DIN rail connector</b> , 5-pos., color: similar to RAL 7035	ME 18.8 TBUS 1.5/5-ST-3.81KMGY	2201813	50
<b>Coding profile</b> , for header and push-in plug, color: natural	CP-DMC 1.5-THR NAT	1790647	60

### 4 Technical data

#### Electrical data

DIN rail connector, nominal voltage	125 V
DIN rail connector, nominal current	Maximum 8 per position
No. of positions	5

#### Housing type

Insulation material	Polyamide
Inflammability class according to UL 94	V0
Color	Similar to RAL 7035, light gray
Power dissipation P <sub>V</sub> at 20°C in the horizontal mounting position	Approx. 2.8 W

## 5 Combination of headers and connectors

### 5.1 Connections of headers and connectors

#### Headers

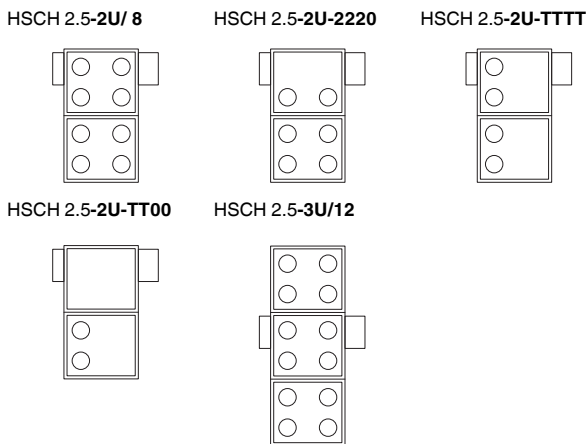
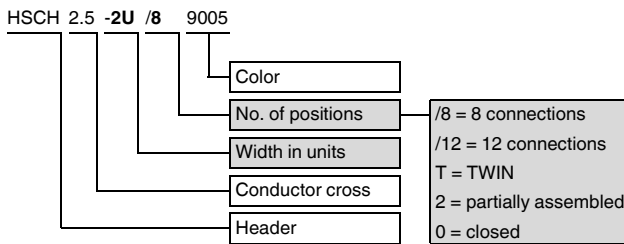

#### Connectors

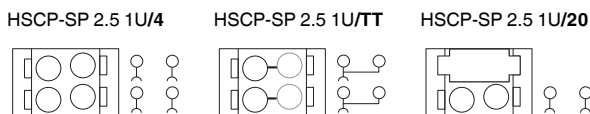
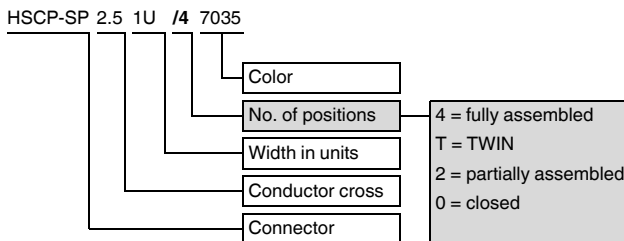

### 5.2 Selecting headers and connectors

The connectors correspond to a unit. For the connectors there are matching headers in 2 or 3 units for soldering onto the PCB.

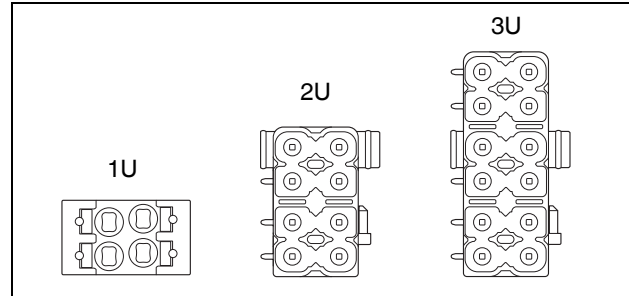

Figure 3 1U connector and 2U + 3U headers

Since the connectors are available in three variants (fully assembled, partially assembled, or TWIN), the connectors have to be suitable for the headers. For the partially assembled connector with two 1U/20 connections, you also have to pay attention to the position in the header.

Headers		Suitable connectors	
	Connections		Number
HSCH 2.5- 2U/8 ...	8	HSCP-SP 2.5 1U/4 ...	2x
HSCH 2.5- 2U-2220 ...	6	HSCP-SP 2.5 1U/4 ...	1x
		1U/20 ...	1x
HSCH 2.5- 2U-TTTT ...	4	HSCP-SP 2.5 1U/TT ...	2x
		HSCP-SP 2.5	
HSCH 2.5- 2U-TT00 ...	2	HSCP-SP 2.5 1U/TT ...	1x
		Housing cover ME-IO 18.8 C 3U S1 7035	1x
HSCH 2.5- 3U/12 ...	12	HSCP-SP 2.5 1U/4 ...	3x

You can also code the connectors so that they are not connected incorrectly by accident (see “Coding the connectors” on page 20).

### 5.3 Concatenating headers

The headers must be concatenated in a way that makes it possible to attach the Lock and Release system, which is available in different lengths (3U – 9U).

The headers have guide pins, which have to fit into the recesses of the Lock and Release system.

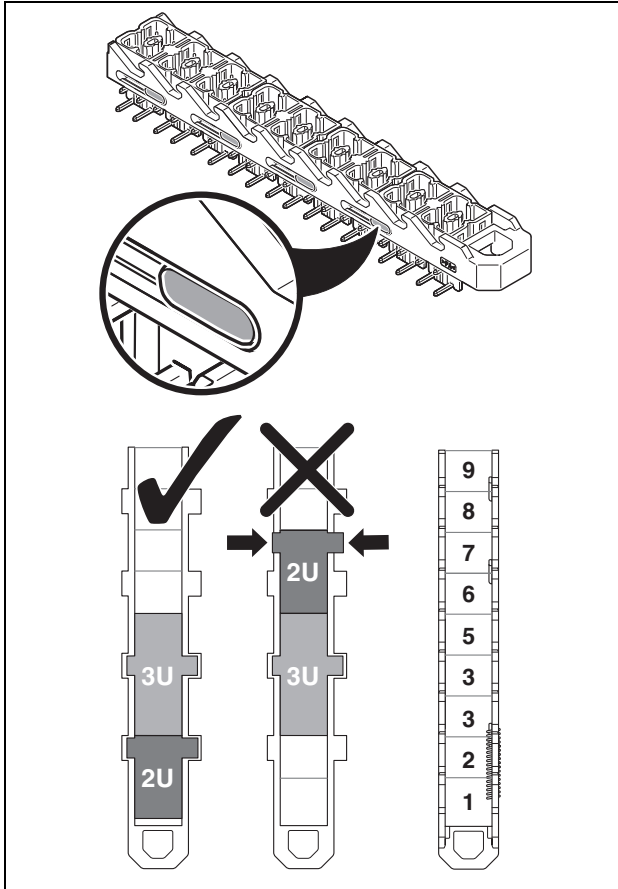

Figure 4 Guide pin and Lock and Release system

The housing is designed for 9 units. The headers can only be concatenated at certain positions. In doing so, it is important to pay attention to the combination of the headers so that the guide pins fit into the Lock and Release system.

It is therefore not possible to concatenate the 3U headers directly because the guide pins will then no longer fit into the Lock and Release system. For the same reason, 2U headers must always be placed **in front of** the 3U headers, e.g. the 2U on position 1 + 2 and the 3U header on positions 3 - 5.

In addition to the headers, housing covers can also be equipped, which are available in 2 to 7 unit versions. Their position can be chosen freely.

### Possible positions of 3U headers

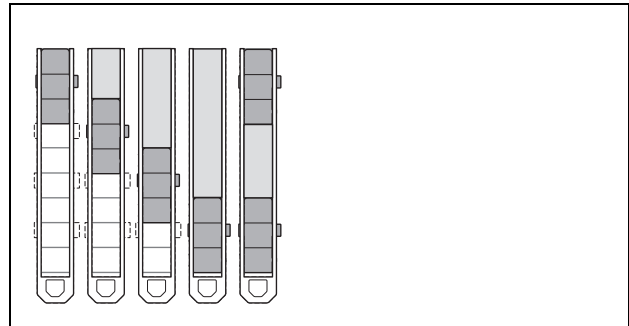

Figure 5 Possible position and combination of HSCCH 2.5-3U... 3U headers

In Figure 5 the possible positions of the 3U headers are displayed. It shows that a direct concatenation of 3U headers is not possible.

In front of the 3U headers it is possible to concatenate 2U headers; housing covers are equipped before and between them.

### Possible positions of 2U headers

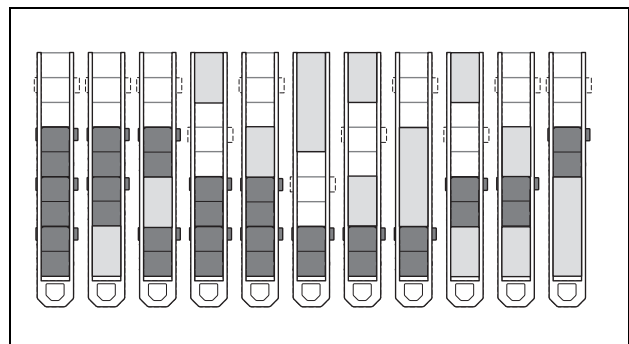

Figure 6 Possible positions and combinations of HSCCH 2.5-3U... 2U headers

The 2U headers can also be directly concatenated. Figure 6 shows all possible positions. You can use the different variants of the 2U header for this purpose.

3U headers fit to some extent on the unoccupied positions behind the 2U headers (see Figure 4 and Figure 5). In addition, housing covers can be equipped. When doing so, make sure that there are no 1U housing covers.

## 6 Dimensions

### 6.1 External dimensions

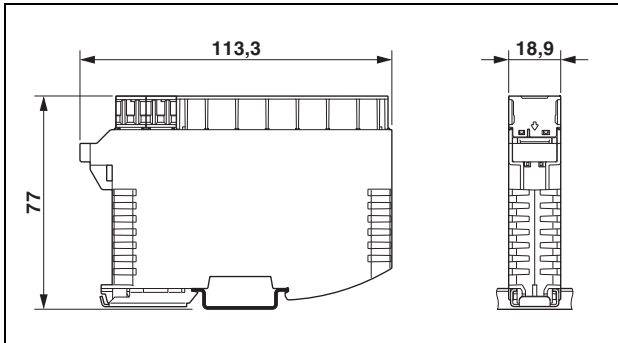

Figure 7 External dimensions of lower housing part with housing cover

### 6.2 Internal dimensions of lower housing part

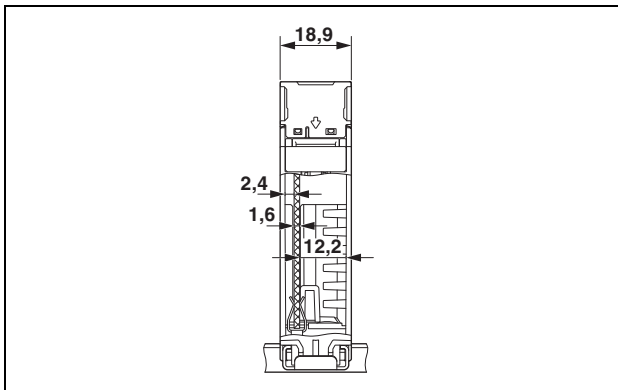

Figure 8 Lower housing part, internal view

### 6.3 Dimensions of the housing cover

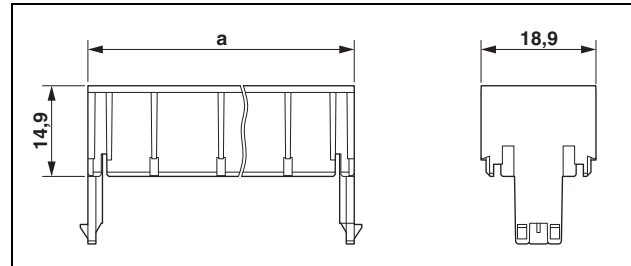

Figure 9 Dimensions of the housing cover

ME-IO 18.8 C 2U 7035	22 mm
ME-IO 18.8 C 3U 7035	33 mm
ME-IO 18.8 C 3U S1 7035	33 mm
ME-IO 18.8 C 4U 7035	44 mm
ME-IO 18.8 C 5U 7035	55 mm
ME-IO 18.8 C 6U 7035	66 mm
ME-IO 18.8 C 7U 7035	77 mm

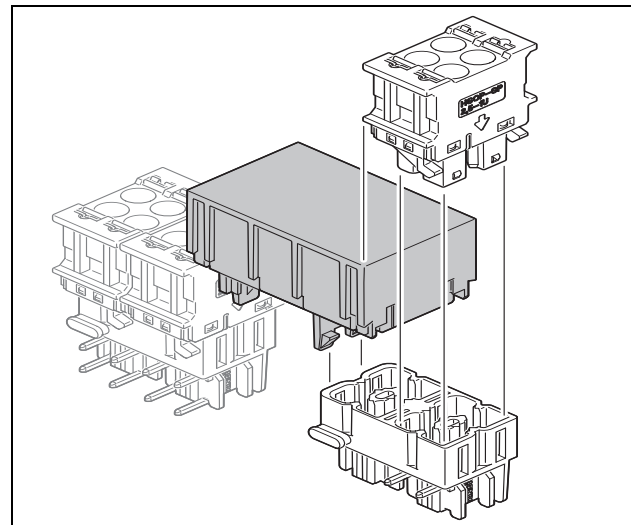

Figure 10 Housing cover ME-IO 18.8 C 3U S1 7035

The housing cover ME-IO 18.8 C 3U S1 7035 is used for covering a unit of the header. The snap-in hook is therefore positioned at an offset of 1 unit. The HSCH 2.5-2U-TT00 header is suitable for this. At the position to be covered there are no connectors in the header.

The cover can however also be used for all other headers.



## 7 PCB dimensions

### 7.1 Maximum PCB dimensions in the lower housing part

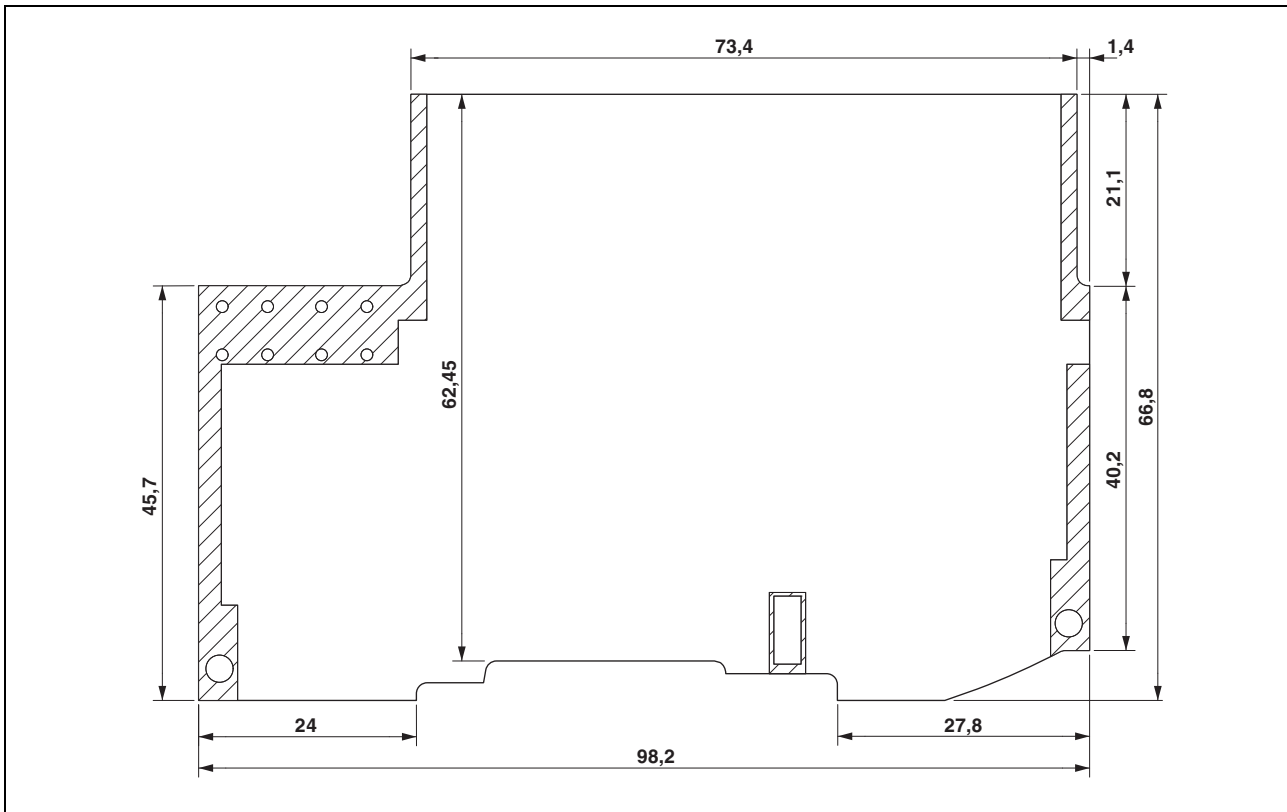
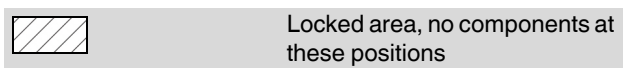

Figure 11 Maximum dimensions of the PCB **without** use of the DIN rail connector, with housing cover 7U



## 7.2 Maximum PCB dimensions with DIN rail connector

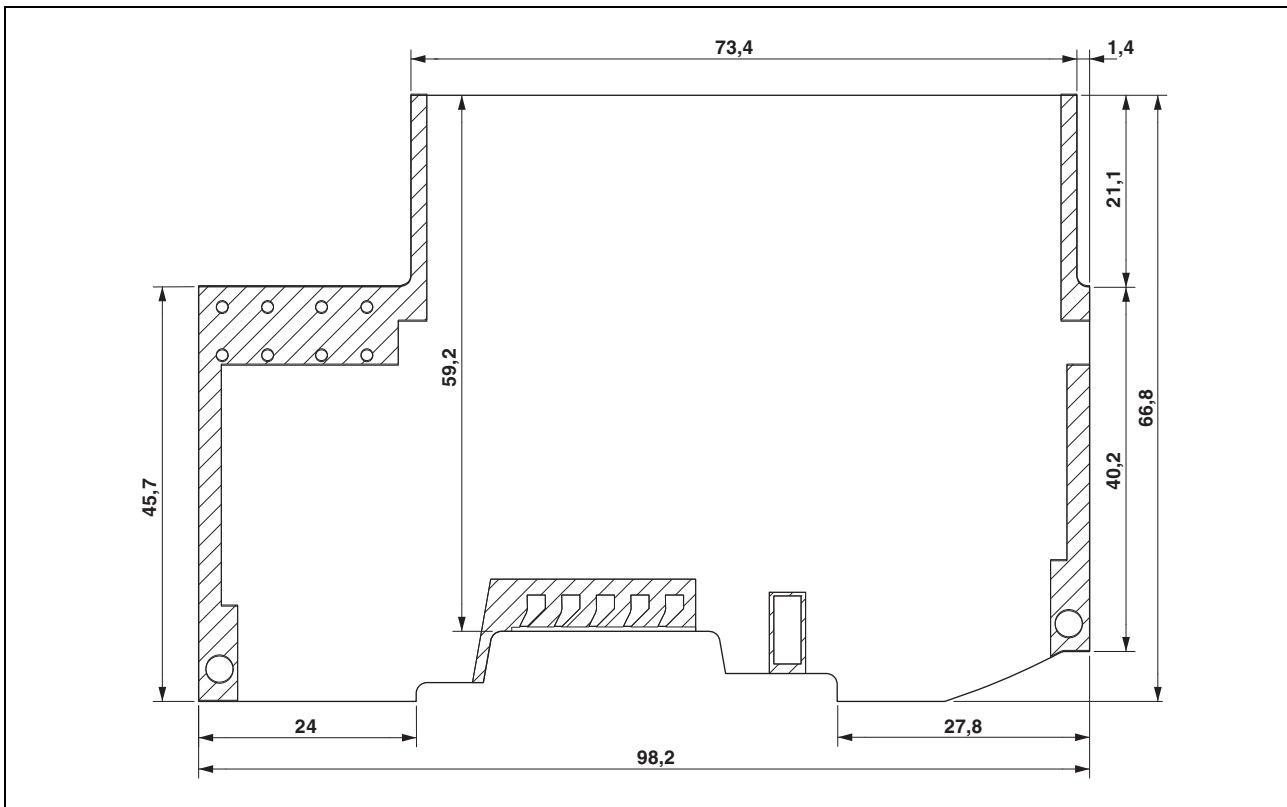
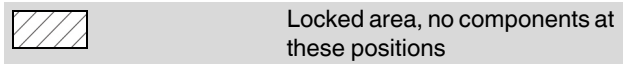

Figure 12 Maximum dimensions of the PCB **with** use of the DIN rail connector, with housing cover 7U

The dimensions of the contact pads can be found in "DIN rail connector" on page 17.



### 7.3 PCB dimensions according to housing cover

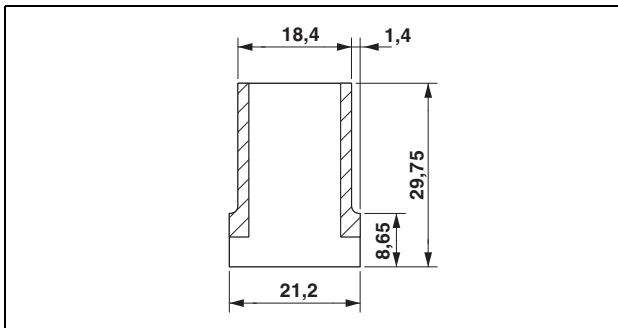

Figure 13 Dimensions of the PCB for housing cover ME-IO 18.8 C 2U 7035 and ME-IO 18.8 C 3U S1 7035

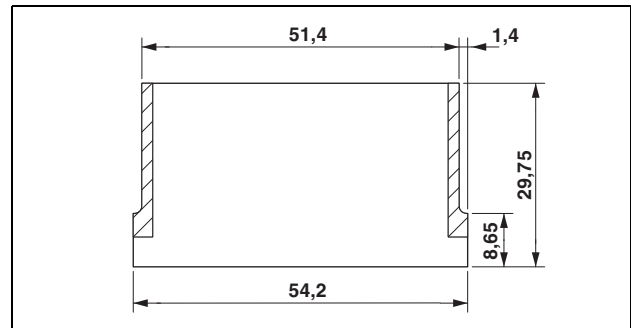

Figure 16 Dimensions of the PCB for housing cover ME-IO 18.8 C 5U 7035

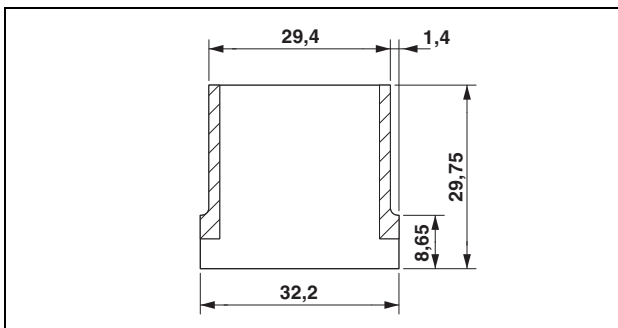

Figure 14 Dimensions of the PCB for housing cover ME-IO 18.8 C 3U 7035

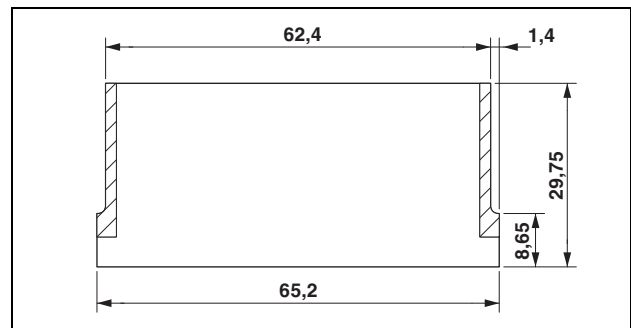

Figure 17 Dimensions of the PCB for housing cover ME-IO 18.8 C 6U 7035

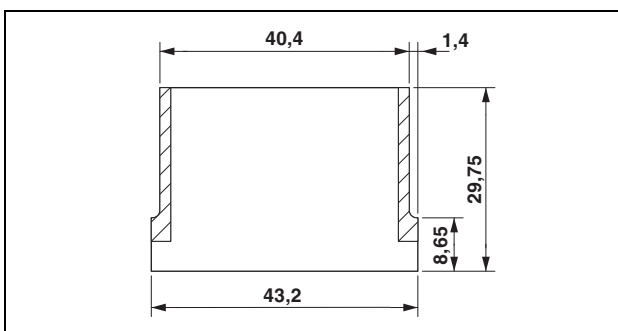

Figure 15 Dimensions of the PCB for housing cover ME-IO 18.8 C 4U 7035

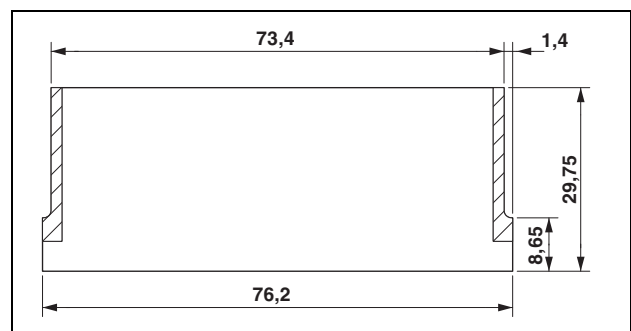
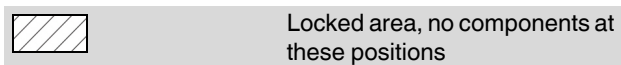

Figure 18 Dimensions of the PCB for housing cover ME-IO 18.8 C 7U 7035



#### 7.4 PCB with FE contact

The FE contact establishes the contact between the electronics module and the DIN rail in order to discharge electromagnetic interference.

The lower housing part is delivered with a pre-assembled FE contact. A pad has to be equipped on the PCB for this purpose (FE contact pad with tin surface; Sn 2-4 $\mu$ m).

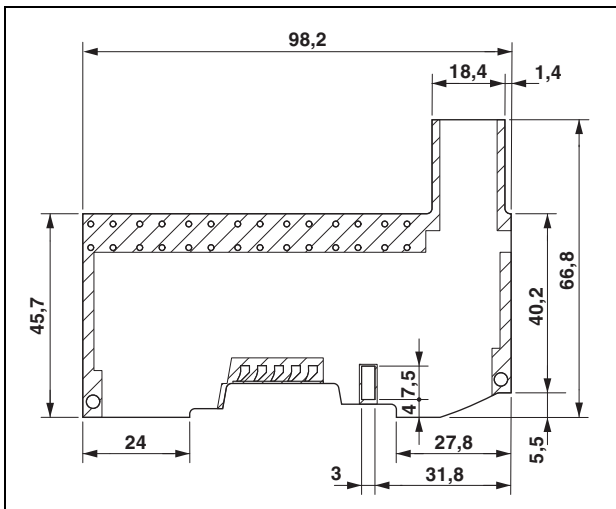
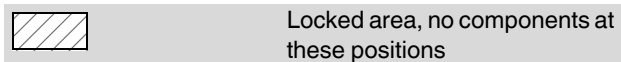

Figure 19 Dimensions of the PCB for FE contact and housing cover 2U



## 8 Connection technology

### 8.1 Header

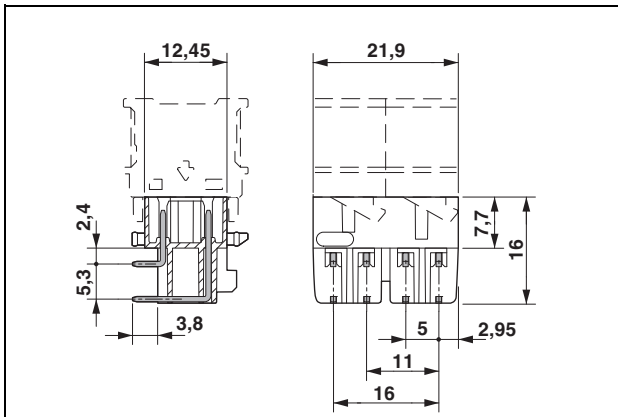

Figure 20 Dimensions of header HSCH 2.5-2U/ 8 9005

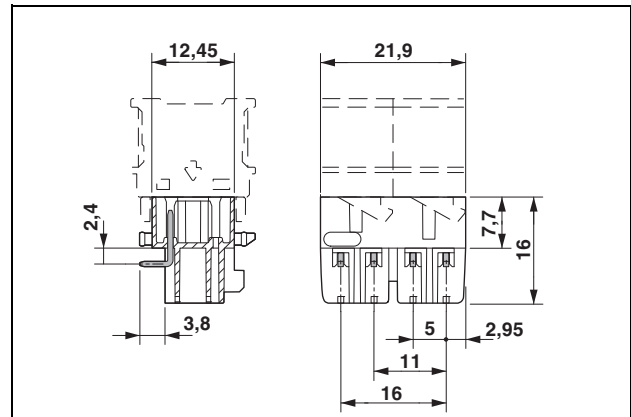

Figure 22 Dimensions of header HSCH 2.5-2U-TTTT 9005

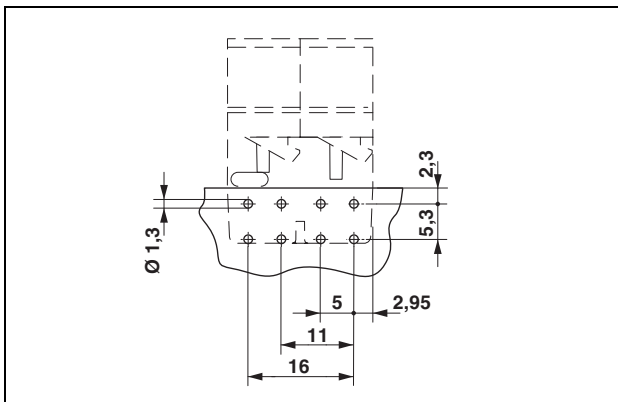

Figure 21 Drilling diagram of header HSCH 2.5-2U/ 8 9005

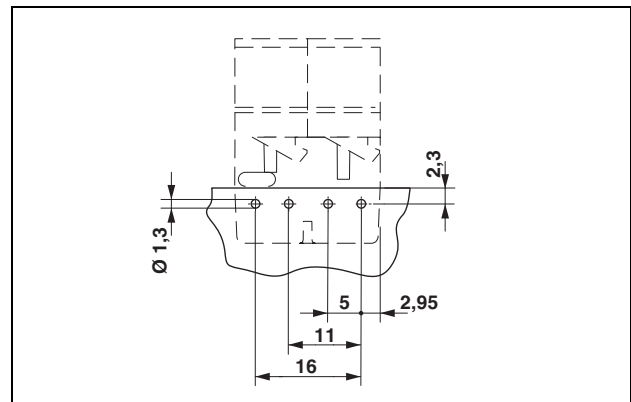

Figure 23 Drilling diagram of header HSCH 2.5-2U-TTTT 9005

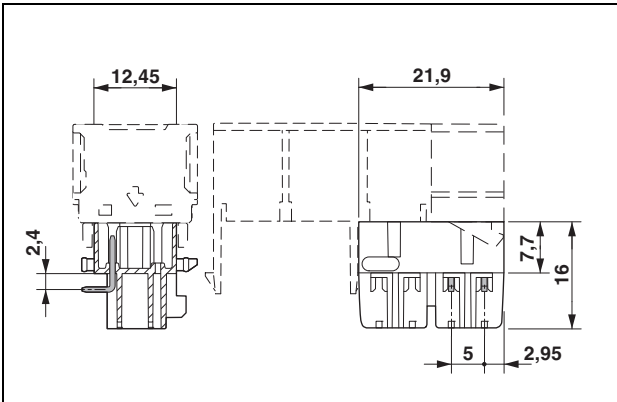

Figure 24 Dimensions of header  
 HSCH 2.5-2U-TT00 9005 with housing cover  
 ME-IO 18.8 C 3U S1 7035

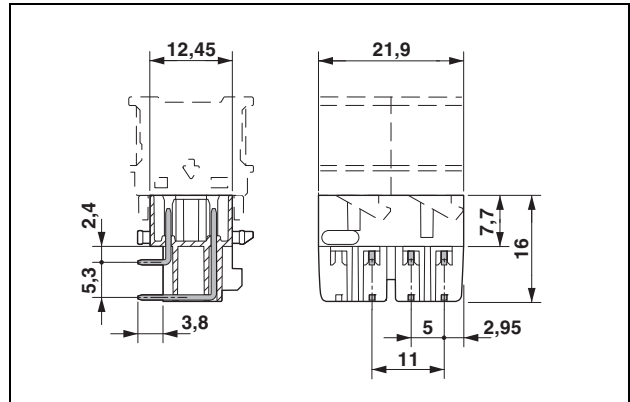

Figure 26 Dimensions of header  
 HSCH 2.5-2U-2220 9005

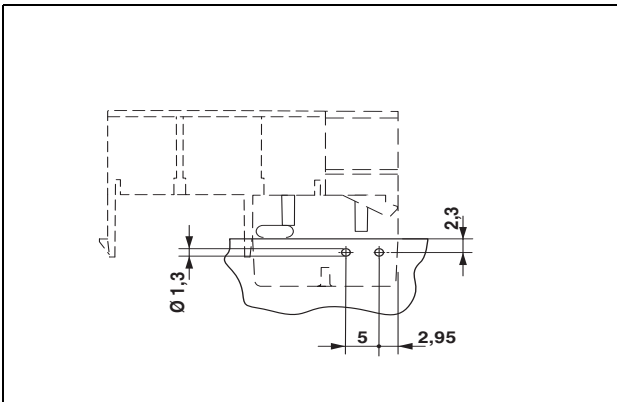

Figure 25 Drilling diagram of header  
 HSCH 2.5-2U-TT00 9005 with housing cover  
 ME-IO 18.8 C 3U S1 7035

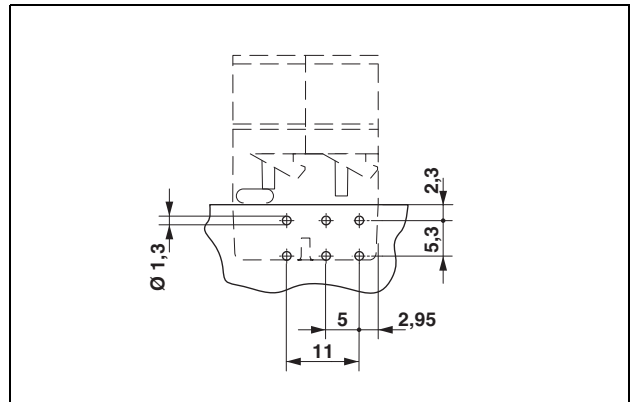

Figure 27 Drilling diagram of header  
 HSCH 2.5-2U-2220 9005

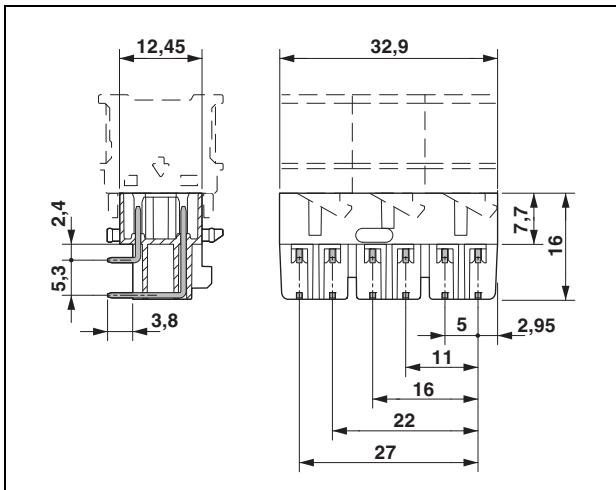

Figure 28 Dimensions of header HSCH 2.5-3U/ 12 9005

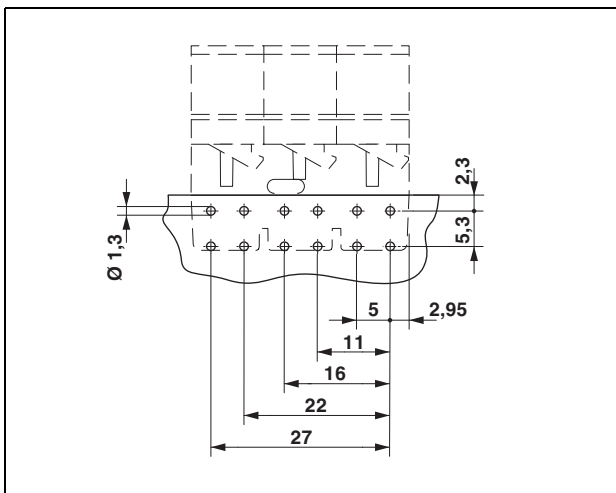

Figure 29 Drilling diagram of header HSCH 2.5-3U/12 9005

**HSCH 2.5-...****Dimensions / Positions**

Pitch 5 mm

No. of positions

HSCH 2.5-2U/ 8 9005	8
HSCH 2.5-2U-TTTT 9005	4
HSCH 2.5-2U-TT00 9005	2
HSCH 2.5-2U-2220 9005	6
HSCH 2.5-3U/12 9005	12

**Technical Data**

Insulation material group I (CTI 600)

Rated surge voltage (III/3) 4 kV

Rated surge voltage (III/2) 4 kV

Rated surge voltage (II/2) 2.5 kV

Rated voltage (III/3) 250 V

Rated voltage (III/2) 300 V

Rated voltage (II/2) 600 V

Connection according to standard DIN EN 61984

Nominal current  $I_N$ , depending on the connector used 8 A

Insulation material PA

Inflammability class according to UL 94 V0

Color RAL 9005, black

**Mask for wave soldering process**

The header protrudes from the PCB on the soldering side. Be aware of this protrusion during the wave soldering process. The protrusion has to be covered by the soldering mask.

## 8.2 Connector

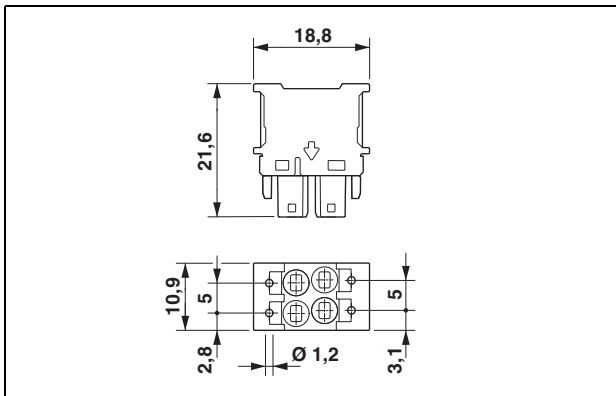

Figure 30 Dimensions of the connector  
HSCP-SP 2.5 1U/TT 7035

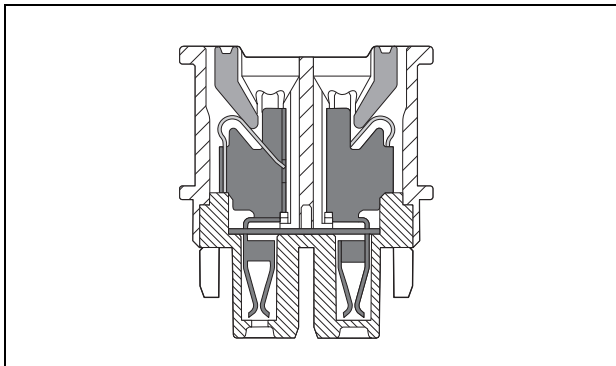

Figure 31 Cross section connector with TWIN connection  
HSCP-SP 2.5 1U/TT 7035

### Test connection



For the test connection we recommend the test probe PS-MT 1-S4-B RD, 1982800. Observe the rated voltage of the test probe of 60 V.

### Color variants and labeling



The spring levers can be requested in different colors.  
The connector surface can be labeled.

## HSCP-SP 2.5

### Dimensions / Positions

No. of positions	
HSCP-SP 2.5 1U/4 7035	4
HSCP-SP 2.5 1U/TT 7035	2 TWIN
HSCP-SP 2.5 1U/20 7035	2

### Technical Data

Insulation material group	I (CTI 600)
Rated surge voltage (III/3)	4 kV
Rated surge voltage (III/2)	4 kV
Rated surge voltage (II/2)	2.5kV
Rated voltage (III/3)	250 V
Rated voltage (III/2)	300 V
Rated voltage (II/2)	600 V
Connection in acc. with standard	DIN EN 61984
Nominal current $I_N$	8 A
Nominal cross section	1.5 mm <sup>2</sup>
Insulation material	PA
Inflammability class in acc. with UL 94	V0

### Connection data

Stripping length w/o ferrule	8 mm ... 9.5 mm
Ferrule	8 mm ... 10 mm
Conductor cross section, solid	0.20 mm <sup>2</sup> ... 1.5 mm <sup>2</sup> ; AWG 24 ... 16
Conductor cross section, stranded	0.20 mm <sup>2</sup> ... 2.5 mm <sup>2</sup> ; AWG 24 ... 14
Conductor cross section, stranded, with ferrule, w/o plastic sleeve	0.25 mm <sup>2</sup> ... 1.5 mm <sup>2</sup> ; AWG 24 ... 16
Conductor cross section, stranded, with ferrule, with plastic sleeve	0.25 mm <sup>2</sup> ... 1.5 mm <sup>2</sup> ; AWG 24 ... 16



### 8.3 DIN rail connector

It is possible to combine the housings with a DIN rail connector (TBUS) by means of which data or the power supply can be transmitted from module to module.

The DIN rail connector is simply laid into the DIN rail NS 35/7.5 and the housing is snapped onto it.

This concept allows complete individual devices to be removed from the group without interrupting the contact chain.

In addition, the DIN rail connector is compatible with the ME-MAX and ME-TBUS housing ranges.

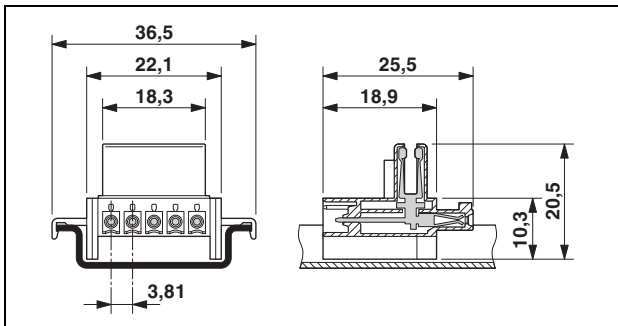

Figure 32 Dimensions of DIN rail connector

### ME 18.8 TBUS 1.5/5-ST-3.81KMGY

#### Dimensions / Positions

Pitch	3.81 mm
No. of positions	5

#### Technical Data

Insulation material group	I (CTI 600)
Rated surge voltage (III/3)	2.5 kV
Rated surge voltage (III/2)	2.5 kV
Rated surge voltage (II/2)	2.5 kV
Rated voltage (III/3)	125 V
Rated voltage (III/2)	160 V
Rated voltage (II/2)	320 V
Connection according to standard	DIN EN 61984
Nominal current $I_N$	8 A
Nominal voltage $U_N$	125 V
Insulation material	PA
Inflammability class according to UL 94	V0

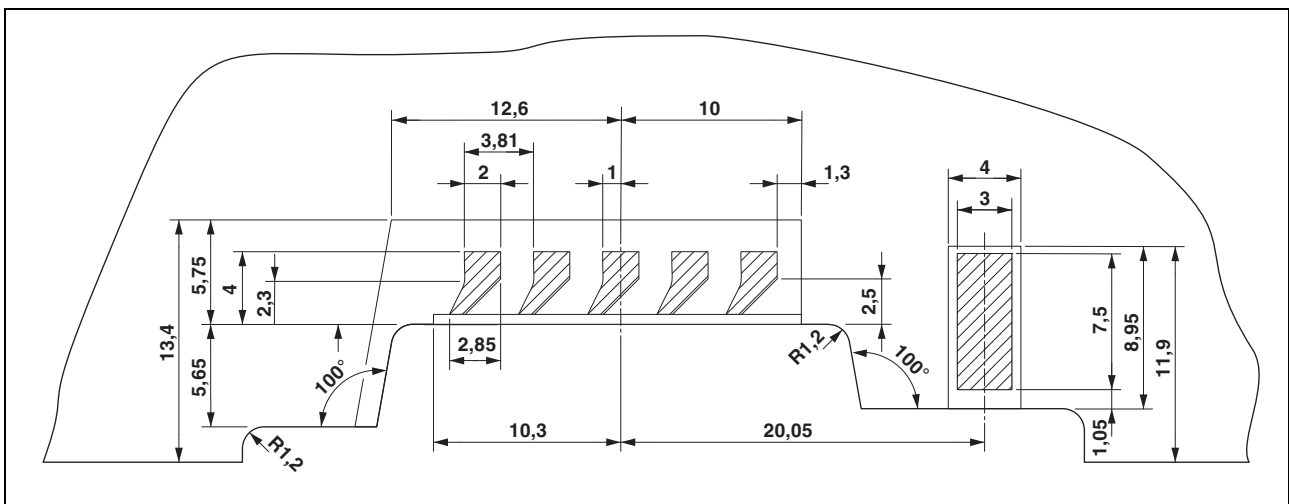

Figure 33 Detailed dimensional drawing of the contact pad of the DIN rail connector

## 9 Mounting the housing

### 9.1 Assembling the Lock and Release system

When the PCB is completely assembled, the orange Lock and Release system, included in the scope of delivery of the lower housing part, has to be assembled.



Pay attention to the positioning of the connectors and the headers (see page 6).

To do this, proceed as follows:

- Solder the header onto the PCB.

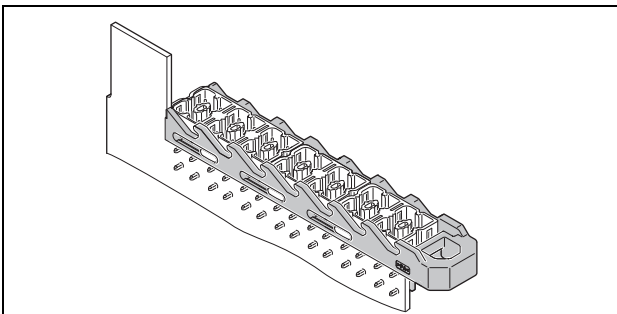

Figure 34 Attaching the Lock and Release system

- Attach the orange Lock and Release system onto the header. The recesses of the Lock and Release system have to fit over the protruding guide pins of the header. Press the Lock and Release system against the header.

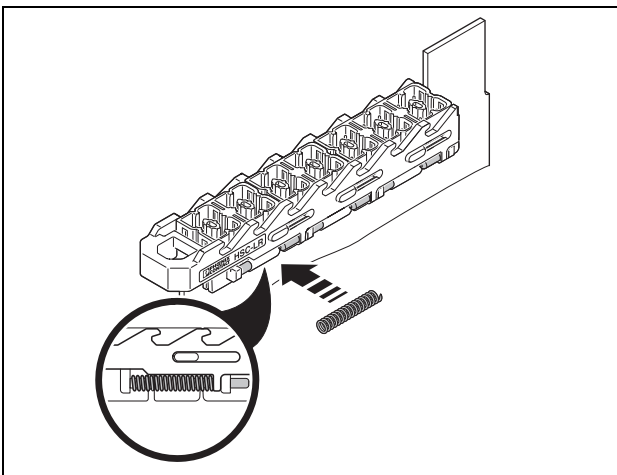

Figure 35 Attaching the spring

- Attach the spring which is included in the scope of delivery. The spring is inserted at one of the possible positions.

### 9.2 Inserting the PCB

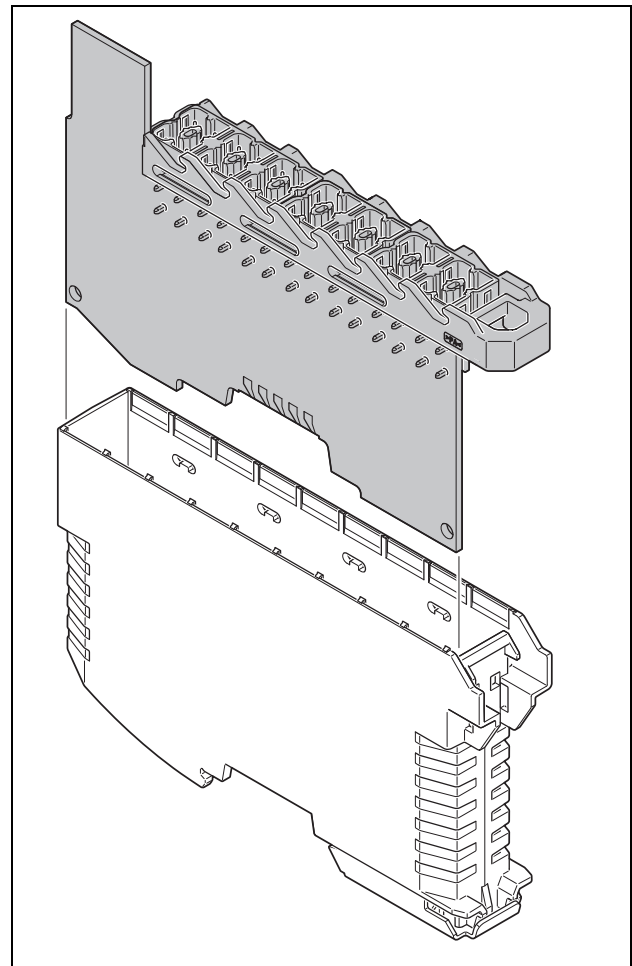

Figure 36 Inserting the PCB

- Insert the PCB into the guide slot of the housing and push it downwards until it audibly snaps in.

### 9.3 Assembling the housing covers

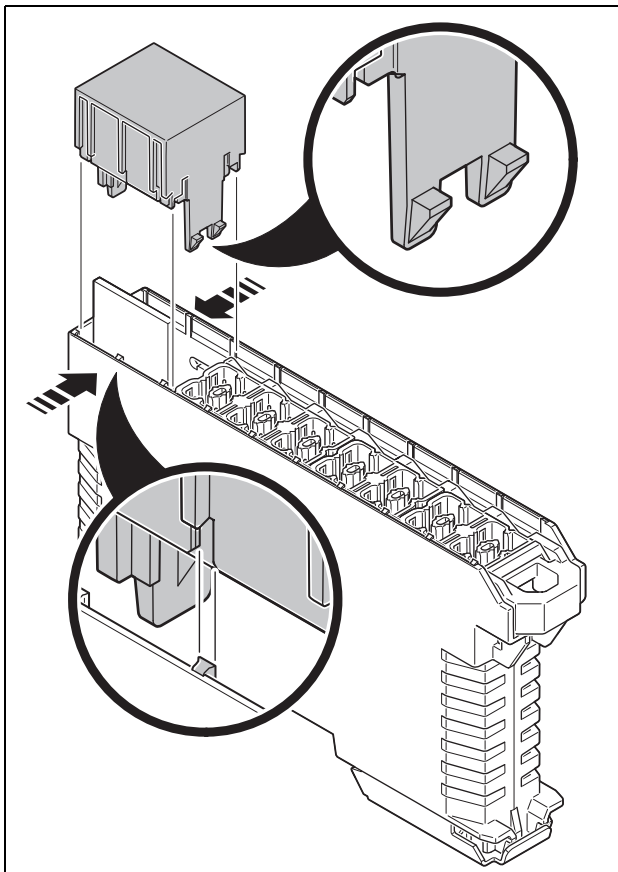

Figure 37 Attaching the housing cover

- Attach the housing covers if they are equipped. The housing cover has two snap-in hooks on one side and only one on the other side. The side with the two snap-in hooks has to be facing the base latch. Make sure that the concealed side guides are also snapped in. To do so, it helps if you lightly push the sides of the housing together.

### 9.4 Assembling the connectors

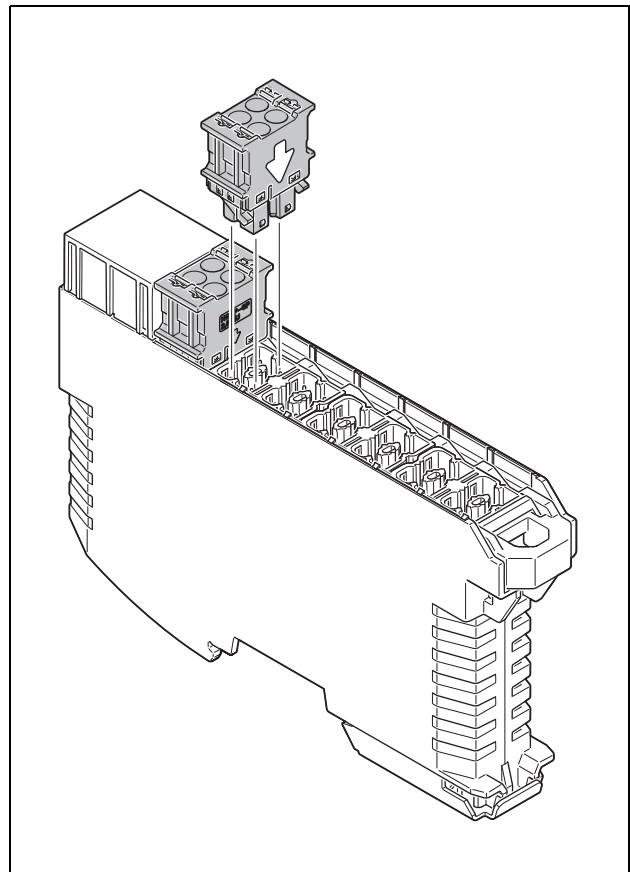

Figure 38 Inserting the connectors

- Insert the connectors. The connectors only fit onto certain headers and can also be coded. Each connector has an engraved arrow that has to be facing the base latch.

### 9.5 Releasing the connectors (Lock and Release)

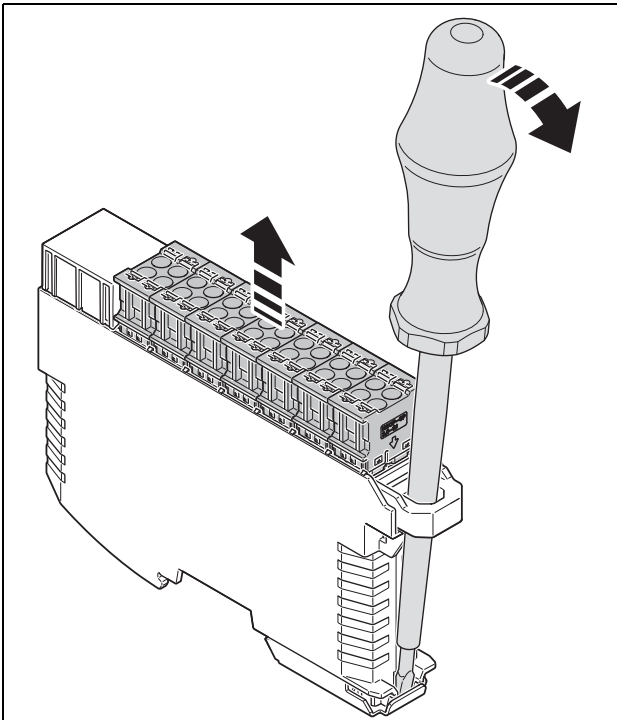

Figure 39 Releasing the connectors



**WARNING: Electric shock**

Make sure that the module is free of current.

- Insert a screwdriver through the opening of the Lock and Release system.
- Hook the tip of the screwdriver into the base latch.
- Pull the screwdriver forward to release the Lock and Release system.

The connectors are lifted and the contact is released.  
But the connectors do not fall out.

The housing cover remains in its position.

### 9.6 Coding the connectors

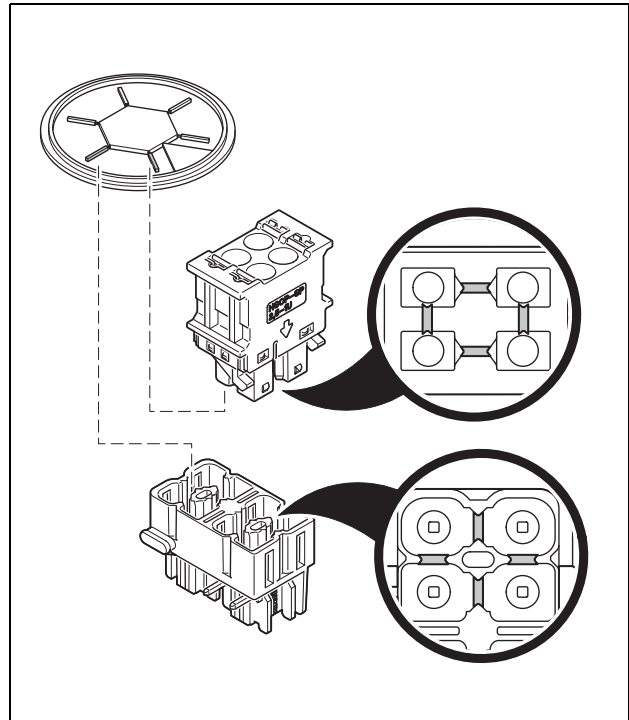

Figure 40 Coding the connectors

You can code the connectors and the headers in order to prevent them from being connected incorrectly by accident. For each connector there are four possible positions where a coding plate can be attached.

Use the coding profile CP-DMC 1.5-THR NAT, 1790647.

- Insert a coding plate at the correct position and twist it off the pentagonal holder.

### 9.7 Connecting conductors (push-in connection)

#### Conductor cross section 1.5 mm<sup>2</sup> ... 2.5 mm<sup>2</sup>, solid or with ferrule

- Insert the stripped wire into the round opening of the terminal block without using a tool.

#### Wires with a smaller cross section or stranded conductors without ferrule

- Push in the pushbutton with a screwdriver to open the spring.

#### Disconnecting

- Push in the pushbutton with a screwdriver to release.
- Pull out the conductor.

We recommend using a bladed screwdriver SZS 0.4X2.5 VDE, 1205037.

### 9.8 Mounting the housing on a DIN rail

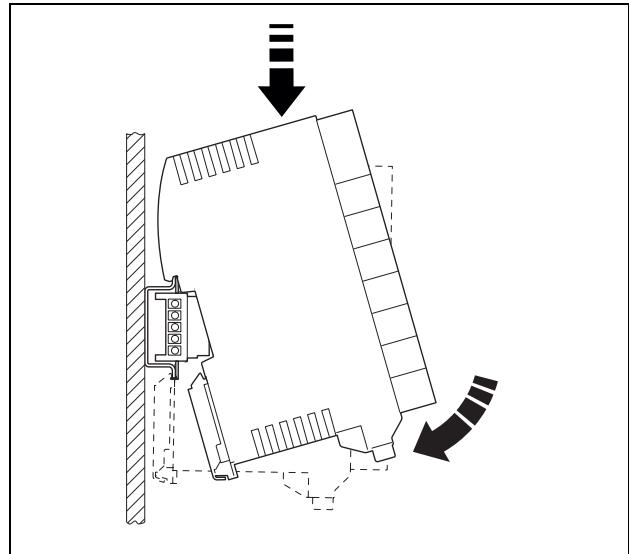

Figure 41 Snapping the housing onto the DIN rail

#### Assembly

- If you use a DIN rail connector, then lay it into the DIN rail with the protruding connector side facing left.
- Place the device onto a grounded 35 mm DIN rail from above so that the upper housing slot hooks onto the top edge of the DIN rail.
- Press the device carefully at the top of the housing towards the mounting surface.
- Once the snap-on foot has audibly snapped onto the DIN rail, check whether it is securely attached.

## 10 Removing the housing

### 10.1 Taking the housing off the DIN rail

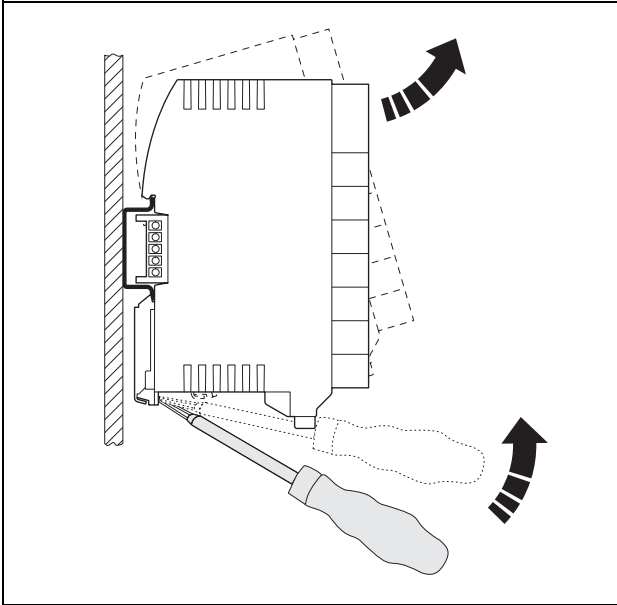

Figure 42 Releasing the housing from the DIN rail

- Release the connectors with the aid of the Lock and Release system (see page 20).
- Make sure that the module is free of current.
- Pry the module off the DIN rail.

### 10.2 Removing the housing covers

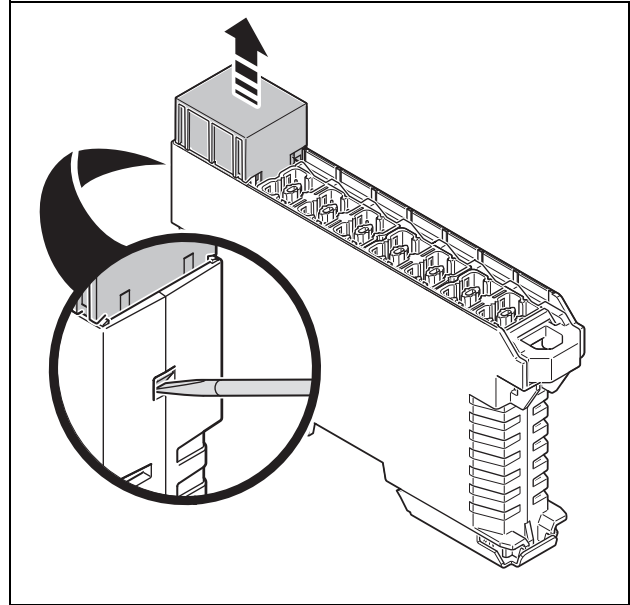

Figure 43 Removing the housing covers

#### Housing cover snapped into the lower housing part on one side

- Push in the snap-in hooks on the slim side of the housing with a screwdriver.

#### Housing cover is located between headers

- A housing cover between the headers is removed together with the PCB.  
See "Taking out the PCB" on page 23.

### 10.3 Removing the base latch

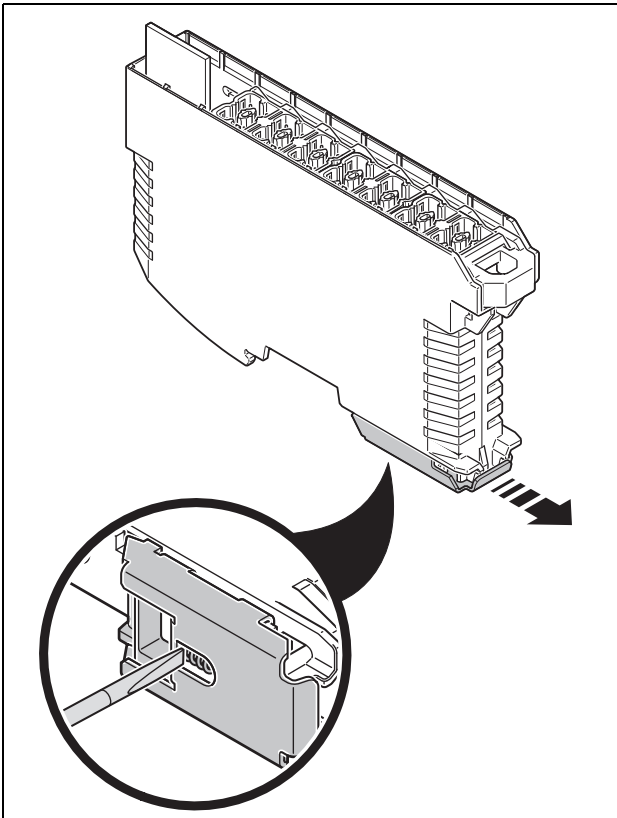

Figure 44 Removing the base latch

- To do so, you must first remove the spring, e.g. with a screwdriver.
- Then pull off the base latch.

### 10.4 Taking out the PCB

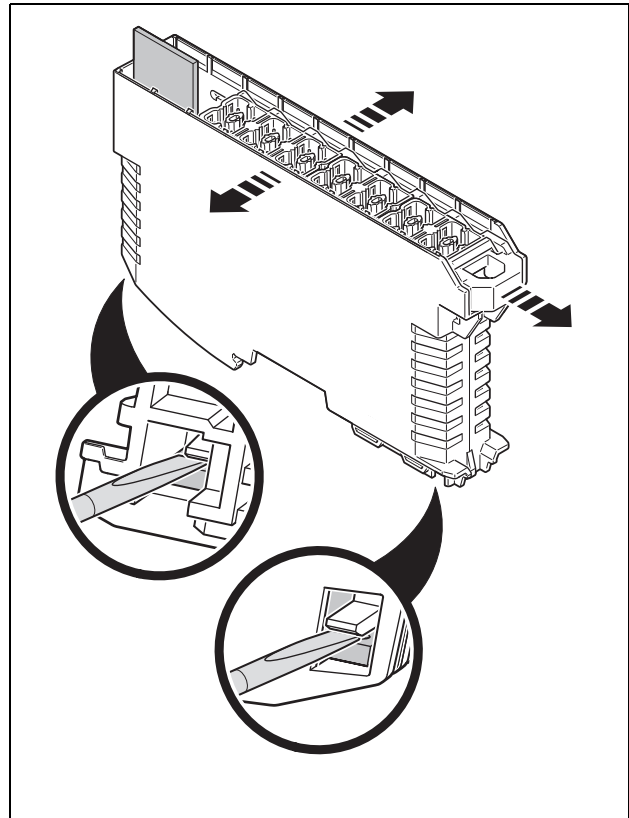

Figure 45 Taking out the PCB

- On the bottom of the housing there are two openings at the outermost ends. Release the catch mechanism there using a screwdriver. Keep both catch mechanisms open.
- To remove the PCB, you have to slightly bend the housing wall up while pulling the Lock and Release system forward at the same time.
- Pull the PCB out.

## 10.5 Taking off the Lock and Release system

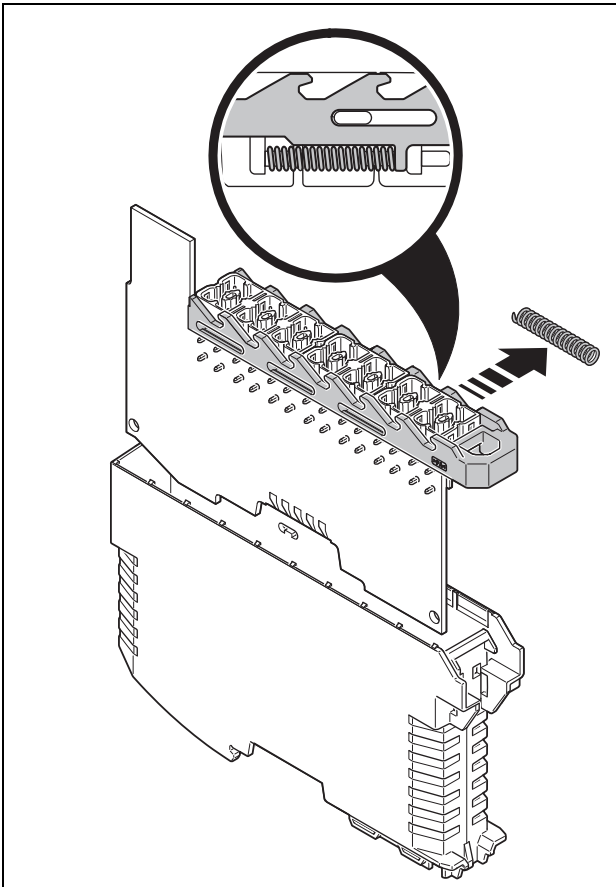

Figure 46 Taking off the Lock and Release system

- Remove the spring and take off the orange Lock and Release system.  
It is easiest to take off when you push it so that the guide pins of the header are positioned in the center of the recesses of the Lock and Release system.